

LIFTAIRE II ELEVATOR AIR CONDITIONER

76°

75°

**THE LATEST IN A SERIES OF AIR CONDITIONERS/HEATERS
DESIGNED SPECIFICALLY FOR USE IN ELEVATORS.**

74°

Airxcel™, the maker of the #1 brand of air conditioners in the recreational vehicle industry, has incorporated its unique experience and small air conditioner technology into building an elevator air conditioner/heater that is now in operation in over 20 countries and 100 cities around the world.

73°

The LiftAire™ II Elevator Air Conditioner is the only cost-efficient alternative for first class comfort control in today's elevators. The lightweight, packaged unit mounts on top of the elevator and is supplied with a kit that includes everything you need for installation.

72°

During operation, supply air is delivered in a cross-flow pattern from the top of the elevator, down to the floor and back up to the ceiling mounted return air duct.

71°

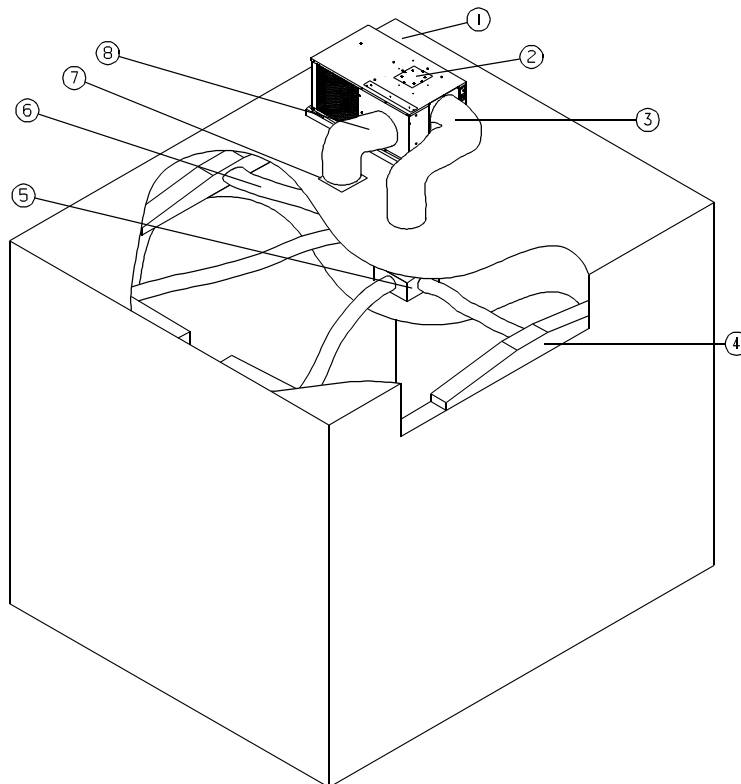

In one easily installed package, the LiftAire™ II Elevator Air Conditioner provides comfort, environmental compliance and cost efficiency with engineered features that include an adjustable thermostat mounted inside the return air flex duct, construction that limits vibration and a lightweight, compact rotary compressor.

By the way, did we mention the LiftAire™ II Elevator Air Conditioner also has a high efficiency heater engineered, prewired and mounted for year-round comfort, at no additional charge!

70°

69°

68°

67°

66°

65°

- | | |
|--------------------------------|-------------------------------|
| ① condenser air outlet | ⑤ plenum box |
| ② optional top cold air outlet | ⑥ four inch flex duct |
| ③ end cold air outlet | ⑦ ten inch return air adaptor |
| ④ conditioned air diverter | ⑧ return air duct |

SERVICE INFORMATION

We believe that you will be pleased with the performance of the RVP LiftAire™ Elevator Air Conditioner. This unique product was specifically designed for installation on elevators. Should you need assistance in the installation of the product, or should you need service assistance after the unit is installed, please contact our exclusive sales and service agent for this product line listed below:

For Installations In North America:

Elevator Motors Corporation
80 Carolyn Blvd.
Farmingdale, NY 11735-1525

631-293-4220 (Voice)

631-293-2714 (Fax)

info@elevatormotors.com (E-Mail)

Attention: Mark or Robert Lane

For Installations Outside North America:

Global Elevator Products, Inc.
P.O. Box 147
Plainview, NY 11803-0147

516-932-7968 (Voice)

516-932-0987 (Fax)

info@globalelevator.com (E-Mail)

LIFTAIRE II™ ELEVATOR AIR CONDITIONER

FEATURES

- Lightweight unit mounts easily in virtually any position on top of the elevator.
- Self-contained, packaged design for easy installation.
- Compact rotary compressor saves space and weight.
- Rated at 14,000 BTUH nominal cooling capacity.
- Mechanical heat/cool thermostat mounted in return air flex duct for secure settings and more accurate temperature sensing. 15' umbilical for remote thermostat mounting. Optional automatic changeover heat/cool thermostat available.
- Standard 1600 watt electric heater delivers 5,600 BTUH heat capacity on 120 volt model; 2,600 watt model delivers 8,800 BTUH heating capacity on 240 volt model.
- Fan can be set to operate continuously for improved air circulation and filtration.
- 450 cubic feet per minute airflow rate.
- Compressor hermetically sealed at factory for leakproof refrigerant flow and efficient operation.
- Black finish on supply air diverter conceals it in the gap between the false ceiling and interior wall.
- Compressor and outer cabinet are mounted on shock absorbing rubber for added durability and noise reduction.
- Long lasting copper tubing is fabricated with shock loops to strengthen the system's vibration resistance.
- Gas-flux brazed joints on the tubing to resist corrosion.
- Start circuit with start capacitor and relay makes starting easier on the compressor.
- All galvanized steel construction of the outer cabinet ensures corrosion resistance.
- Heavy-duty, galvanized steel drain pan is specially designed for corrosion-resistant durability with bronze-brazed corners and powder-coated corners and powdered-coated epoxy paint.
- Freeze protection is provided to prevent evaporator freeze-up, along with high and low pressure switches to protect against fan failure or refrigerant loss.
- 4-pin connector plugs into air conditioner for easy thermostat hookup.
- Field wiring accomplished simply and easily to lugs on Printed Circuit Board.
- Washable filter drops into return air bonnet.
- Normally open contact for remote monitoring of unit shutdown or power outages.

OPTIONAL ACCESSORIES

- Automatic Thermostat - Programmable for 7-day operation, on/off, heat/cool
- Condensate Evaporator - 1/60/115 volt or 1/50/240 volt, 3,000 watts complete with pan, filter, overflow tube and connection cables
- Overflow Detection Device

SPECIFICATIONS

Nominal BTUH Cooling Capacity.....	14,000	14,000
Delivered BTUH Heating Output.....	5,600	8,800
Electrical Rating.....	1/60/115V	1/50/240V

Locked Rotor Cooling Amps.....	67*	32*
Approximate Full-Load Amps/Cooling.....	16.1*	8.0*
Approximate Full-Load Amps/Heating.....	15.7*	12.0*
Running Watts (1).....	1,537	1,576
Running Watts (2).....	1,909	1,933
Running Watts/Heating.....	1,600	2,600
Evaporator Air Delivery CFM (high speed).....	450	450

- (1) Tested under the following conditions: Cooling A.R.I. Standard Conditions 80°F. DB/67°F. WB Indoor, 95°F. DB Outdoor at 115 VAC.
- (2) Tested under the following conditions: Cooling A.R.I. Standard Conditions 95°F. DB/71°F. WB Indoor, 115°F. DB Outdoor at 103.5 VAC.

Coleman is a registered trademark of The Coleman Company, Inc. used under license. Mach is a registered trademark and LiftAire is a trademark of Recreation Vehicle Products.

* Air conditioner only. Does not include condensate evaporator.

For more information about the LiftAire, in North America, contact:

Elevator Motors Corporation
 80 Carolyn Blvd.
 Farmingdale, NY 11735-1525
 Phone (631) 293-4220
 Fax (631) 293-2714
 E-Mail: info@elevatormotors.com

For more information about the LiftAire, outside North America, contact:

Global Elevator Products Corporation
 P.O. Box 147
 Plainview, NY 11803-0147
 Phone (516) 932-7968
 Fax (516) 932-0987
 E-Mail: info@globalelevator.com

Length	39"
Width	23"
Height	18 1/8"
Weight	A/C Unit 180 lbs. Installation Kit 38 lbs.

Length	21"
Width	13"
Height	7"
Weight	20 lbs.

