

EM200AB

No.	LTR	REVISION/DESCRIPTION	DATE	CHECKED BY

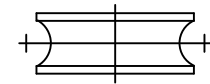

PER ASME A17.1 SECTION 2.20
WIRE ROPE WEDGE SOCKET ASSEMBLY

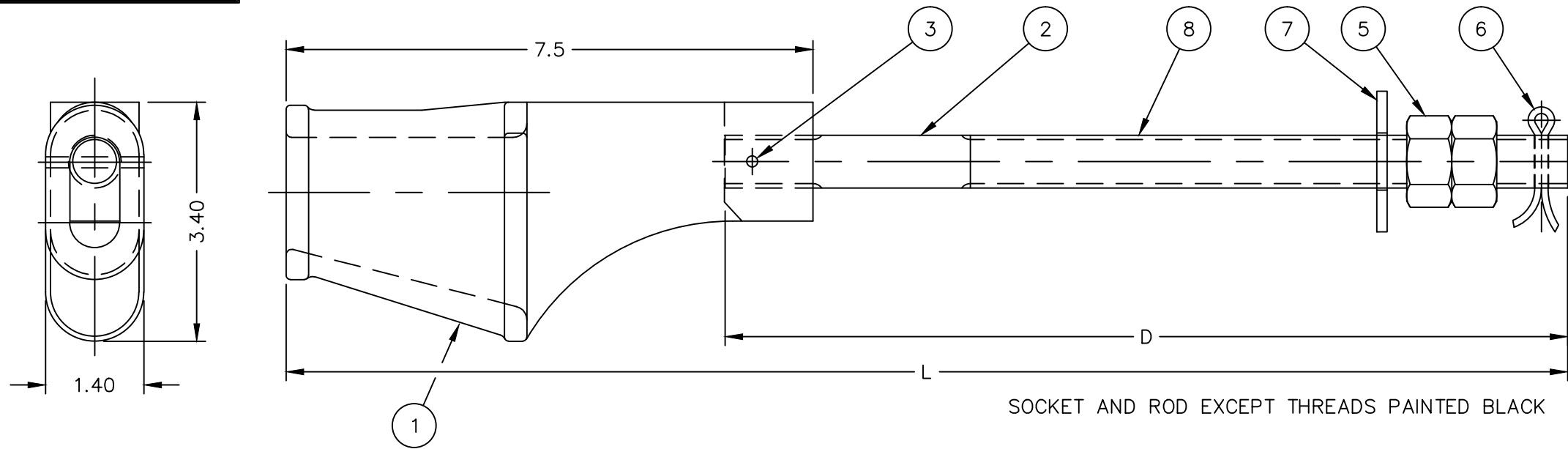
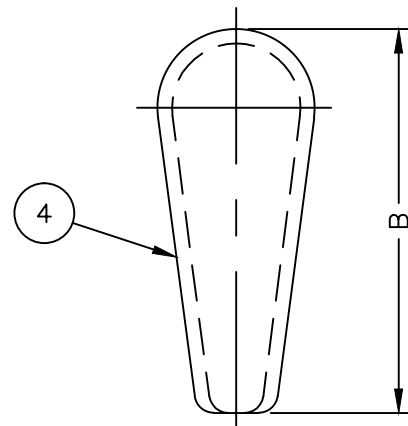

P/N'S: EM201A & EM202
WEDGE INSERT

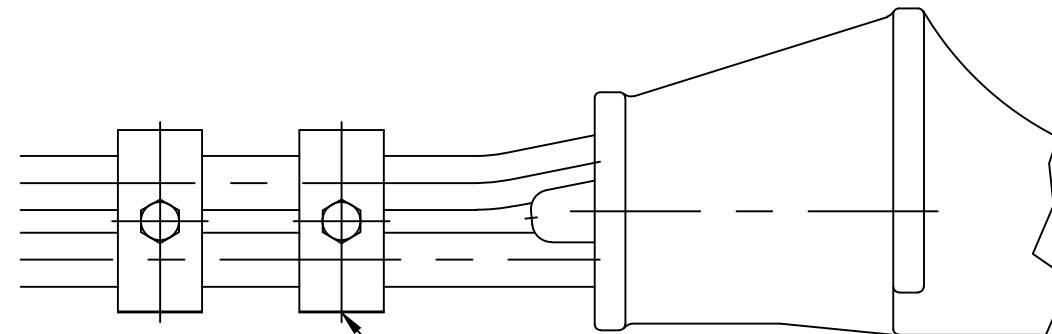

EM203 WIRE ROPE RETAINING CLIPS
(2) REQUIRED

REF	DESCRIPTION
1	SOCKET
2	ROD
3	ROLL PIN
4	WEDGE
5	NUT
6	COTTER PIN
7	WASHER
8	THREADS

DATE	PART	DESCRIPTION	B	L	D
05/MAY/01	EM201A	1/2 INCH-13mm WEDGE INSERT	4	-	-
	EM202	5/8 INCH-16mm WEDGE INSERT	4.7	-	-
	EM200-12	WIRE ROPE WEDGE SOCKET		18.25 INCH	12.0 INCH
	EM200-18			24.25 INCH	18.0 INCH
	EM200-24			30.25 INCH	24.0 INCH
	EM200-30			36.25 INCH	30.0 INCH
	EM200-36			42.25 INCH	36.0 INCH
	EM200-42			48.25 INCH	42.0 INCH
	EM200-24 FL THD	WIRE ROPE WEDGE SOCKET		30.25 INCH	24.0 INCH

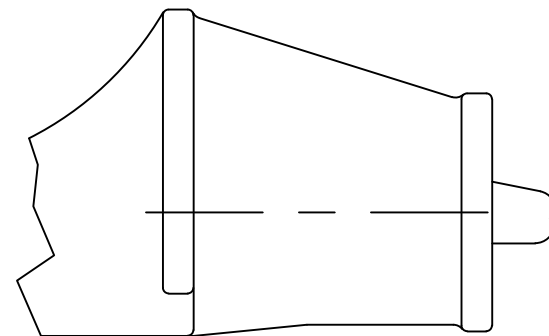

This drawing is the property of ELEVATOR MOTORS CORPORATION
Do not print, photograph, copy or use for any purpose other than that which it is specifically furnished



7/16"-1/2"-9/16"-5/8", 11mm-16mm
EMCO-200 WIRE ROPE WEDGE SOCKET ASSEMBLY

R.S.P.	---	07/AUG/01	1" = 2"	1 of 1
DRAWN BY	CHECKED BY	DATE	SCALE	SHEET No.
DWG. No.	EM200AB			C
				REV LTR.

EM200AB